

The Crystal Structure of 2,2,4,4-Tetramethyl-1,3-cyclobutanedithione

BY CHARLES D. SHIRRELL AND DONALD E. WILLIAMS

Department of Chemistry, University of Louisville, Louisville, Kentucky 40208, U.S.A.

(Received 1 February 1973; accepted 21 March 1973)

The crystal structure of 2,2,4,4-tetramethyl-1,3-cyclobutanedithione ($C_8H_{12}S_2$) has been determined from three-dimensional X-ray diffraction data. The crystals are tetragonal, space group $P4_2/mnm$, with $Z=2$, cell dimensions $a=6.330$ (1) and $c=12.549$ (4) Å. Data were collected on a diffractometer using zirconium-filtered Mo $K\alpha$ radiation. The structure was solved by interpretation of a sharpened Patterson map and refined by full-matrix anisotropic least-squares analysis to a R value of 0.094. The molecular symmetry in the crystal is mmm , with a planar cyclobutane ring. The bond lengths corrected for thermal motion (assuming a rigid body) are: C–C(ring)=1.531 (8); C–CH₃=1.529 (6); and C=S=1.608 (8) Å. The bond angles in the ring are 93.5 (6)° and 86.5 (5)°.

Introduction

The cyclobutane ring exists in both planar and puckered conformations in the solid state. Infrared and Raman studies have indicated that the nonplanar conformation of these rings is more favorable than the planar conformation (Rathjens, Freeman, Gwinn & Pitzer, 1953). However, many cyclobutane rings have been found to be planar in the solid state.

Molecules which are centrosymmetric and can therefore occupy a crystallographic center of symmetry usually contain planar rings (Soltzberg & Margulis, 1971). An interesting case has been discovered for the disodium salt of *trans*-1,3-cyclobutanedicarboxylic acid (Adman & Margulis, 1968) which crystallizes with two neutral acid molecules of crystallization. The neutral acid (Margulis & Fisher, 1968) was found to have a planar ring when crystallized by itself and a puckered ring when crystallized with the sodium salt. Thus it is clear that planarity or nonplanarity is more than an intrinsic characteristic of the molecule; it is related to intermolecular forces. To gain more information about the nature of these forces in simple crystalline cyclobutane compounds, we have undertaken a study on the conformation of several thiones and ketones of cyclobutane.

Experimental

A sample of 2,2,4,4-tetramethyl-1,3-cyclobutanedithione ($C_8H_{12}S_2$) was prepared in our laboratory using the method of Elam & Davis (1967). The crystals used in this study resulted from cooling a solution in a 1:1 mixture of hexane and pyridine. Crystallization from many other organic solvents was attempted, but good single crystals were not obtained. The identity of our crystals with an authentic sample (kindly provided by Dr Elam) was confirmed by mixed melting point, infrared, and n.m.r.

Approximate cell dimensions, systematic absences ($0kl$: $k+l$ odd), and tetragonal symmetry were noted

from oscillation and Weissenberg photographs taken with nickel-filtered Cu $K\alpha$ radiation. The photographic data were taken using two crystals; one was rotated around the a axis and the other was rotated around the c axis. The possible space groups were $P4_2/mnm$, $P4n2$, $P4_2nm$. The centric space group $P4_2/mnm$ was initially chosen and later confirmed by the successful structure determination.

The crystal used for accurate lattice constant and intensity data was a cylindrical dark-red polyhedron of approximate dimensions $0.4 \times 0.4 \times 0.3$ mm. It was mounted in a Lindemann capillary tube with the 0.3 mm axis (c) parallel to the walls of the capillary tube. The crystals were extremely volatile and often sublimed and reformed on the walls of the capillary tube.

Using vanadium-filtered Cr $K\alpha$ ($\lambda=2.2916$ Å), 10 reflection angles with high 2θ values were accurately determined with a scintillation counter detector. The lattice constants were determined by a least-squares fit (Williams, 1964) to these data using the extrapolation function of $\Delta\theta_1 = K_1 \sin(2\theta)$ where $\Delta\theta_1$ is the systematic error in θ and where K_1 is the extrapolation coefficient. This is equivalent to a linear extrapolation of a plot of d vs $\cos^2(\theta)$ to $\theta=90^\circ$. This function can be used to correct for eccentricity of the sample (Parrish & Wilson, 1967). The values obtained for room temperature (23°C) were $a=6.330$ (1) and $c=12.549$ (4) Å. The volume of the unit cell is 502.79 Å³, and the calculated density for two molecules of $C_8H_{12}S_2$ (F.W. 172.32) is 1.138 g cm⁻³. The observed density, measured by flotation in an aqueous solution of potassium iodide, was 1.14 g cm⁻³.

The intensities of 412 independent reflections (up to $2\theta=60^\circ$) were measured with a Siemens manual diffractometer using zirconium-filtered Mo $K\alpha$ radiation ($\lambda=0.7107$ Å). The diffraction unit was equipped with a single-crystal orienter, scintillation counter and a pulse-height analyzer. Intensities were measured using the θ - 2θ scan technique. The scan rate was $1^\circ/\text{min}$. The background was measured before and after each reflection. The take-off angle was 3.3° , and the re-

ceiving slit was 4 × 4 mm. A check of the intensities of several reflections selected as standards showed them to remain constant within statistical and instrumental fluctuations during the data-taking period. The Lorentz and polarization corrections were made in the usual manner. For Mo K α X-rays, the linear absorption coefficient for this compound is 4.47 cm⁻¹. No absorption correction was made.

The standard deviation of each intensity measurement was estimated by the formula:

$$\sigma^2(I) = CT + CB + (0.05 \cdot CT)^2 + (0.05 \cdot CB)^2$$

where CT is the total counts and CB is the background counts. The error in the structure factor, $\sigma(F_o)$, was calculated from $\sigma(I)$ by the finite-difference method (Williams & Rundle, 1964). If CT < CB, then F_o was set equal to zero. In the least-squares refinement the weight of each reflection was taken as 1/ $[\sigma(F_o)]^2$.

Structure determination

The observed systematic absences do not lead to a positive identification of the space group; $P4_2n2$,

$P4_2nm$, and $P4_2/mnm$ are all possibilities. However, the peaks on a sharpened Patterson map can be explained by assuming a planar molecule whose four-membered ring lies in the diagonal mirror plane (x, x, z) and which possesses mmm symmetry.

Therefore, as an initial assumption a trial model of the compound with the maximum permitted symmetry was constructed; its molecular center was located at the origin of space group $P4_2/mnm$. Owing to the symmetry of the molecule and the space group, this implies that it is necessary to locate one methyl carbon atom, two ring carbon atoms, and one sulfur atom. To be consistent with the Patterson-map S(1) and C(2), one of the ring carbon atoms, must be placed along $x, x, 0$; the remaining ring carbon atom, C(3), must be located on 0, 0, z ; and the methyl carbon atom, C(4), must be located on x, \bar{x}, z .

The atomic positions obtained from the Patterson map were refined initially with isotropic temperature factors; and in the later cycles, with anisotropic ones. A modification of the full-matrix least-squares program of Busing, Martin & Levy (1962) was used in this process. The function minimized in the least-squares

Table 1. Final atomic positions and anisotropic thermal vibrational parameters ($\times 10^4$) and their estimated standard deviations

$$T = \exp [-(B_{11}h^2 + B_{22}k^2 + B_{33}l^2 + 2B_{12}hk + 2B_{13}hl + 2B_{23}kl)]$$

	x	y	z	B ₁₁	B ₂₂	B ₃₃	B ₁₂	B ₁₃	B ₂₃
S(1)	2945 (6)	2945 (6)	0	497 (17)	497 (17)	171 (3)	-203 (7)	0	0
C(2)	1157 (17)	1157 (11)	0	305 (22)	305 (22)	84 (4)	-8 (16)	0	0
C(3)	0	0	885 (5)	341 (15)	341 (15)	63 (3)	-17 (17)	0	0
C(4)	1407 (15)	-1407 (15)	1557 (3)	579 (21)	579 (21)	69 (4)	78 (19)	3 (10)	116 (12)
H(5)	2403	-2403	1107			Same as C(4)			
H(6)	589	-2444	2062			Same as C(4)			

Table 2. Structure factors

The values of $[10 \cdot K \cdot F_o]$ and $10 \cdot F_c$ are given.

H 1 0	0 5 10	4 0 3	6 0 -9	2 0 7	4 0 -19	2 28 21	H 5 6	H 5 7	H 5 8	5 8 2	0 9 -3	1 52 52	1 3 -10	H 3 15
1 14 -3	5 0 -13	H 7 2	H 7 2	3 7 -6	5 10 30	3 0 -8	H 5 6	H 5 7	H 5 8	2 6 4	1 15 18	2 0 -7	3 21 22	0 10 -3
1 458 450	3 12 5	H 8 1	H 8 1	4 0 23	4 6 -13	4 6 -13	1 30 -34	0 76 -71	1 0 -4	H 6 9	3 0 2	H 2 12	4 0 -7	1 7 -9
H 2 0	H 1 1	1 6 11	2 0 0	0 19	H 7 3	0 15 -23	H 6 5	2 0 7	3 13 -15	1 13 0	H 7 10	0 14 12	1 16 15	2 0 -2
0 270 -290	0 298 331	2 0 12	3 0 19	H 7 3	0 42 52	2 19 -21	3 25 -22	2 12 15	4 3 -1	3 5 1	H 7 10	1 16 15	H 5 13	3 8 -9
1 307 323	1 352 -356	3 18 0	4 0 -1	0 9 15	1 18 -15	3 0 -6	5 0 14	4 9 -10	5 15 13	4 0 6	1 0 2	2 29 27	0 0 -6	H 4 15
2 271 284	H 0 2	H 0 2	5 0 -11	0 9 15	4 11 18	5 10 -5	4 19 18	5 0 -4	0 0 -13	H 6 8	H 7 9	H 3 12	1 10 -7	1 12 -2
H 3 0	H 2 1	0 591 591	H 8 2	2 4 -12	3 10 18	4 0 1	0 0 -13	1 20 23	1 26 23	0 0 0	H 7 9	H 3 12	2 13 10	2 10 -3
1 193 190	2 53 -60	H 1 2	2 15 10	H 8 3	1 7 -12	2 0 5	2 26 -19	2 9 -4	3 10 3	0 7 5	H 3 11	1 0 -2	2 13 10	1 12 -2
1 56 -64	2 121 -125	H 1 2	2 15 10	H 8 3	1 7 -12	2 0 5	3 0 -6	3 14 -14	4 11 5	1 0 4	1 50 -55	3 29 24	H 0 14	H 0 16
3 175 179	H 3 1	1 115 127	3 18 4	H 8 3	1 7 -12	2 0 5	4 3 3	4 14 16	5 0 -3	H 7 8	H 2 11	H 4 12	0 31 37	0 0 -20
H 4 0	0 137 141	H 2 2	H 1 3	1 0 3	3 10 9	4 0 0	5 0 -2	5 0 1	5 0 -3	H 7 8	H 0 10	1 42 47	0 8 -11	H 1 14
1 119 118	2 76 -79	0 233 -227	0 269 -250	3 14 -2	H 8 4	H 8 4	3 0 16	3 0 16	4 0 0	H 7 8	H 0 10	2 33 -29	2 15 -7	H 1 14
1 164 -157	3 70 -68	2 260 260	1 673 -626	H 0 4	H 8 4	H 8 4	4 0 -7	4 0 -7	5 0 0	H 1 10	H 3 11	2 11 9	1 6 9	1 8 -13
2 24 21	H 4 1	H 2 3	0 235 216	0 0 -3	H 8 5	H 8 5	1 0 -6	1 0 11	2 0 8	H 1 10	H 3 11	3 6 1	4 20 21	H 2 14
3 62 86	H 4 1	H 2 3	0 235 216	1 0 -5	H 8 5	H 8 5	2 12 4	1 9 2	3 12 -2	H 1 9	H 2 10	0 37 44	H 5 12	0 0 -8
4 50 53	H 3 2	H 2 3	1 132 130	2 0 4	H 1 5	H 1 5	3 12 -2	2 0 -12	3 0 12	H 1 9	H 2 10	1 0 7	H 5 12	0 9 -13
H 5 0	1 56 -54	1 10 1	2 267 -264	H 1 4	H 1 5	H 1 5	4 8 2	3 0 12	0 18 -20	H 2 9	H 2 10	3 12 -4	1 13 1	1 12 7
1 0 26	4 51 -51	3 78 78	H 3 3	1 44 -52	H 1 5	H 1 5	0 0 -1	0 106 157	H 2 9	H 2 9	H 4 11	3 16 13	H 3 14	H 3 16
2 23 23	H 5 1	H 4 2	0 221 216	H 2 4	0 43 -36	0 429 388	0 0 -1	0 106 157	H 2 9	H 2 9	H 4 11	3 16 13	H 3 14	H 3 16
3 11 0	H 5 1	H 4 2	0 221 216	H 2 4	1 292 -273	0 429 388	0 0 -1	0 106 157	H 2 9	H 2 9	H 4 11	3 16 13	H 3 14	H 3 16
4 0 -13	0 97 -97	0 55 55	2 143 -140	1 34 -26	H 2 5	H 1 6	H 1 7	H 1 8	1 33 32	H 3 10	H 3 10	2 10 13	1 11 -9	1 3 -2
5 34 53	1 12 -10	1 136 -137	3 72 -65	2 72 57	H 2 5	H 1 6	H 1 7	H 1 8	2 81 -85	H 3 10	H 3 10	3 0 21	0 18 5	2 14 -10
H 6 0	2 88 92	2 20 -20	4 0 -11	4 13 -16	H 2 5	H 1 6	H 1 7	H 1 8	1 13 9	H 3 10	H 3 10	4 12 -9	1 8 2	H 1 17
0 32 25	4 0 5	4 0 8	H 4 3	H 3 4	H 2 5	H 1 6	H 1 7	H 1 8	3 9 9	H 3 10	H 3 10	2 42 -42	2 16 7	H 4 14
1 43 50	5 13 27	H 5 2	1 42 -43	1 54 -50	H 2 5	H 1 6	H 1 7	H 1 8	0 59 64	H 3 10	H 3 10	3 11 7	H 5 11	0 0 -10
2 7 4	H 6 1	H 5 2	2 40 -49	2 126 -137	H 2 5	H 1 6	H 1 7	H 1 8	0 111 -108	H 4 10	H 4 10	1 3 -11	H 6 12	1 7 -11
3 8 -12	H 6 1	H 5 2	3 35 37	3 0 -3	H 2 5	H 1 6	H 1 7	H 1 8	1 19 19	H 4 10	H 4 10	2 22 -22	0 38 43	2 7 4
4 9 2	1 20 24	2 51 53	4 0 -11	4 13 -16	H 2 5	H 1 6	H 1 7	H 1 8	2 52 52	H 4 9	H 4 9	0 29 35	2 23 16	1 0 0
5 11 -10	2 14 -10	3 19 -23	H 5 3	H 4 4	H 2 5	H 1 6	H 1 7	H 1 8	2 12 -11	H 4 9	H 4 9	1 16 -11	3 0 0	3 9 -2
H 7 0	3 6 1	4 17 -17	0 10 14	H 4 5	H 3 5	H 2 7	H 3 7	H 3 8	0 88 -89	H 4 9	H 4 9	3 14 17	H 6 11	1 8 2
1 16 12	4 24 33	5 24 46	0 101 -98	1 89 -84	H 3 5	H 2 7	H 3 7	H 3 8	1 134 -130	H 4 9	H 4 9	4 0 7	H 6 11	1 8 2
2 0 7	5 0	6 0 -19	1 31 21	2 53 -56	H 3 5	H 2 7	H 3 7	H 3 8	2 57 -55	H 4 9	H 4 9	5 0 0	H 6 11	1 8 2
3 12 20	H 7 1	0 3 5	3 11 5	4 13 -16	H 3 5	H 2 7	H 3 7	H 3 8	3 29 27	H 5 10	H 5 10	1 11 4	H 6 11	1 8 2
4 0 4	H 7 1	0 3 5	3 11 5	4 13 -16	H 3 5	H 2 7	H 3 7	H 3 8	4 40 -39	H 5 10	H 5 10	2 5 2	H 6 11	1 8 2
5 11 -10	0 10 41	2 11 -7	H 6 3	1 20 -22	H 3 5	H 2 7	H 3 7	H 3 8	0 7 -8	H 5 9	H 5 9	3 4 3	H 6 11	1 8 2
H 8 0	1 0 -1	3 16 -16	H 6 3	1 20 -22	H 3 5	H 2 7	H 3 7	H 3 8	1 55 -57	H 5 9	H 5 9	4 0 12	H 6 11	1 8 2
	2 13 -6	4 14 -14	H 6 3	1 20 -22	H 3 5	H 2 7	H 3 7	H 3 8	2 10 -14	H 5 9	H 5 9	5 13 16	0 100 98	3 0 -8
	3 0 23	5 0 -3	1 6 -4	3 37 -35	1 8 2	4 0 4	4 21 -21	4 0 4	3 14 8	H 6 10	H 6 10	1 4 3	2 23 -18	1 4 -6

calculations was $\sum(F_o - |F_c|/K)^2/\sigma^2(F_o)$. After several anisotropic least-squares cycles the weighted R value, $\{[\sum(F_o - |F_c|/K)^2/\sigma^2(F_o)]/[\sum F_o^2/\sigma^2(F_o)]\}^{1/2}$, was 0.115. The scattering factors of Hanson, Herman, Lea & Skillman (1964) were used for S and C.

A difference Fourier map accepting all reflections was run and the hydrogen atoms were located. The anisotropic temperature factors of the hydrogen atoms were set equal to those of the methyl carbon, C(4). The scattering factors of Stewart, Davidson & Simpson (1965) were used for H. Two more cycles of full-matrix anisotropic least-squares refinement resulted in a weighted R value of 0.094. On the last least-squares cycle, all parameters shifted less than 0.1σ . A difference Fourier map was prepared from the final model and the values of this map ranged from $0.27 e \text{ \AA}^{-3}$ to $-0.19 e \text{ \AA}^{-3}$ in a apparently random fashion.

The final atomic parameters are listed in Table 1 together with their estimated standard deviations. A list of the calculated and observed structure factors is given in Table 2.

Discussion

The bond angles and bond distances, not corrected for thermal motion, are given in Fig. 1. Because of symmetry restrictions the cyclobutane ring is square planar. The bond distances were corrected for the effect of thermal motion according to the rigid molecule model of Cruickshank (1961). The screw tensor is zero (Schomaker & Trueblood, 1968) since the molecule has $\bar{1}$ site symmetry. Fig. 2 shows the thermally corrected distances and the orientation of the thermal ellipsoids are plotted by the computer program of Johnson (1965). The thermal corrections to the bond angles were assumed to be negligible.

Fig. 2 also shows the observed eclipsed conformation of the methyl hydrogens, corresponding to $H \cdots H$ nonbonded contacts 2.72 \AA . The shortest transannular $H \cdots H$ contact is 2.78 \AA . The average C-H bond distance, uncorrected for thermal motion, is 1.05 \AA ; the average H-C-H bond angle is 113° .

The angle C(3)-C(2)-C(3') of $93.5(6)^\circ$, is larger than usual for an internal ring angle in a simple cyclobutane compound (Table 3). A comparison with the structure of 2,2,4,4-tetramethyl-1,3-cyclobutanedione (Riche & Janot, 1972) shows that the angle in the dithione is 1.5° smaller than the corresponding angle in the dione compound.

The C-C bond in the ring is shorter than the normal C-C bond. This is unusual since most C-C bonds in simple cyclobutane-ring compounds have longer, not shorter, bonds than normal. Most ring C-C bond lengths lie in the region $1.547\text{--}1.58 \text{ \AA}$ (see Table 3). A rationale for these long bonds was given by Dunitz & Schomaker (1952). Although long bonds are usually the case, an even shorter bond (1.517 \AA) than what we found has been observed in *trans*-1,2-cyclobutanedicarboxylic acid (Benedetti, Corradini & Pedone, 1970).

The 1,3-transannular distance [C(3)-C(3')] is interesting because of the possibility of π interaction between the p orbitals of the 1,3-transannular carbons. The possibility of such an interaction has been discussed by a number of authors (Caserio & Roberts, 1958; Silversmith & Roberts, 1958; Smutny, Caserio & Roberts, 1960; Kosower, 1963; Ferguson & Nnadi, 1965). In the optical absorption spectra of 2,2,4,4-tetramethyl-1,3-cyclobutanedione, the $n \rightarrow \pi^*$ absorption band appears to be split into two components by the 1,3-transannular π interaction; whereas, in the dithione there is no such splitting (Ballard & Park, 1970).

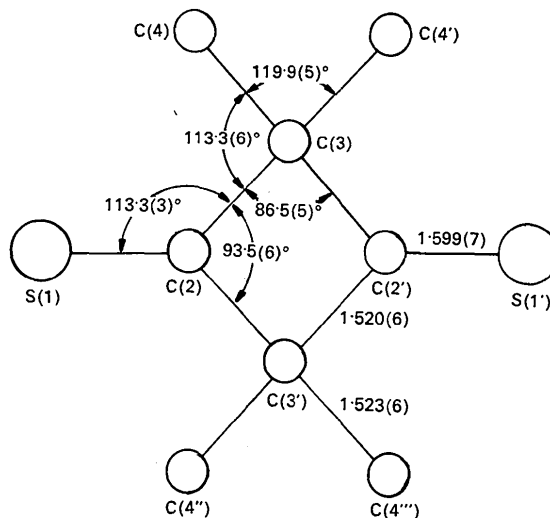

Fig. 1. The bond angles ($^\circ$), bond distances (\AA), and their estimated standard deviation.

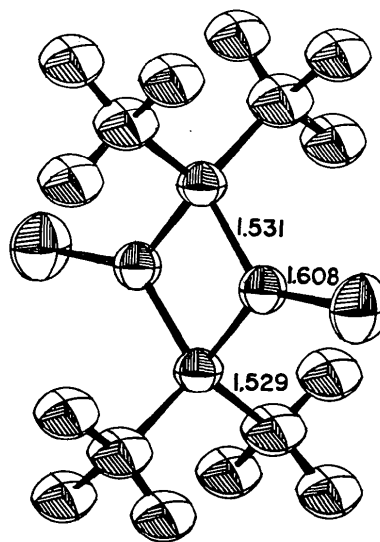

Fig. 2. The thermally corrected distances and the observed hydrogen positions. The thermal ellipsoids enclose a probability density of 0.25.

Table 3. *Crystallographic studies of simple* cyclobutane compounds*

Compound	Maximum molecular symmetry	Observed crystallographic symmetry	Dihedral ring angle†	C-C bond lengths in ring	Thermally corrected lengths	C-C-C bond angles in ring	Reference
2,2,4,4-Tetramethyl-1,3-cyclobutanedione (refinement)	<i>mmm</i>	<i>2/m</i>	180	1.58 (2) 1.54 (2)	—	89.5 90.5	(a)
	<i>mmm</i>	<i>2/m</i>	180	1.540 (7) 1.510 (7)	—	85.0 (4) 95.0 (4)	(b)
<i>cis,trans,cis</i> -1,2,3,4-Tetraphenylcyclobutane (refinement)	<i>mm</i>	$\bar{1}$	180	1.555 (20) 1.585 (20)	—	91.1 (2.0) 88.9 (2.0)	(c)
	<i>mm</i>	$\bar{1}$	180	1.573 (15) 1.566 (15)	—	90.6 (1.0) 89.4 (1.0)	(d)
Octachlorocyclobutane (refinement)	<i>mmm</i>	<i>m</i>	158	1.58 1.60	—	88.7 87.4 87.1	(e)
	<i>mmm</i>	<i>m</i>	161	1.57 (3) 1.58 (3)	—	88.4 (1.0) 89.9 (1.0) 87.8 (1.0)	(d)
<i>cis</i> -1,2-Dibromo-1,2-dimethoxycarbonylcyclobutane	<i>m</i>	1	150	1.52 (27) 1.55 (27) 1.58 (27)	—	89.3 (1.1) 88.6 (1.1) 88.4 (1.1)	(f)
	<i>m</i>	1	153	1.58 (27) 1.52 (27) 1.53 (27)	—	85.5 (1.1) 88.0 (1.1) 89.4 (1.1)	(f)
<i>trans</i> -1,2-Dibromo-1,2-dimethoxycarbonylcyclobutane	2	1	153	1.57 (27) 1.58 (27)	—	87.0 (1.1) 88.1 (1.1)	(f)
	<i>m</i>	1	159.5	1.531 (4) 1.526 (3) 1.546 (3)	1.536 (4) 1.532 (3) 1.550 (3)	90.1 (2) 87.9 (2) 90.7 (2)	(g), (h)
<i>trans</i> -1,3-Cyclobutanedicarboxylic acid	<i>2/m</i>	$\bar{1}$	180	1.556 (4) 1.548 (6)	1.562 (4) 1.552 (4)	86.3 (2) 90.5 (3)	(i)
	<i>mm</i>	$\bar{1}$	180	1.562 (6) 1.547 (3) 1.561 (3)	1.567 (6) —	89.5 (3) 89.8 (2) 90.2 (2)	(j)
<i>cis,trans,cis</i> -1,2,3,4-Tetracyanocyclobutane (Na ⁺) ₂ C ₄ H ₆ (COO ⁻) ₂ · 2C ₄ H ₆ (COOH) ₂ disodium salt of <i>trans</i> -1,3-cyclobutanedicarboxylic acid	<i>2/m</i>	$\bar{1}$	180	1.555 (10) 1.560 (9)	1.559 (10) 1.567 (10)	90.7 (5) 89.3 (5)	(k)
	<i>2/m</i>	1	155	1.550 (9) 1.551 (10) 1.546 (11)	1.553 (9) 1.552 (10) 1.556 (11)	88.2 (5) 88.4 (5) 88.7 (5)	(k)
Octahydroxycyclobutane	<i>mmm</i>	$\bar{1}$	180	1.539 (11) 1.562 (4) 1.564 (4)	1.546 (11) —	89.3 (5) 90.2 (2) 89.8 (2)	(l)
	<i>mm</i>	1	149 (3)	1.545 (12) 1.563 (12) 1.552 (12)	1.549 (12) 1.563 (12) 1.555 (12)	88.0 (6) 87.6 (6) 87.7 (6)	(m)
<i>cis</i> -1,3-Cyclobutanedicarboxylic acid	<i>mm</i>	$\bar{1}$	180	1.547 (12) 1.544 (5)	1.548 (12) 1.545 (5)	88.0 (6) 91.2	(n)
	<i>m</i>	1	156	1.545 (5) 1.552 (6) 1.529 (6)	1.549 (5) —	88.8 88.7 91.1	(o), (p)
<i>trans</i> -1,3-Cyclobutanedicarboxylic acid	<i>mm</i>	$\bar{1}$	180	1.532 (6) 1.550 (6)	—	88.6 87.6	(p)
	2	2	149 (2)	1.553 (4) 1.553 (4)	—	87.5 (2) 88.8 (2)	(q)
<i>cis,trans,cis</i> -1,2,3,4-Cyclobutanetetracarboxylic acid tetramethyl ester	<i>mm</i>	$\bar{1}$	180	1.517 (4) 1.572 (5) 1.541 (4)	—	91.0 (3) 89.0 (3)	(r)
	<i>mm</i>	1	() ‡	1.556 (5) 1.557 (5) 1.522 (5)	—	88.3 (3) 89.5 (3) 90.8 (3)	(s)
2,2,4,4-Tetramethyl-1,3-cyclobutanedithione	<i>mmm</i>	<i>mmm</i>	180	1.524 (5) 1.520 (6)	1.531 (6)	89.4 (3) 93.5 (6) 86.5 (5)	This study

* By simple we mean only those molecules in which the cyclobutane ring is neither conjugated nor fused to another ring.

† Defined as the angle between normals to two three-carbon planes with the transannular distance common to both planes.

‡ This compound is observed to undergo dynamic inversion of ring conformation in the solid state; and it is possible to observe both puckered and planar forms.

Table 3 (*cont.*)

References: (a) Friedlander & Robertson (1956). (b) Riche & Janot (1972). (c) Dunitz (1949). (d) Margulis (1965). (e) Owen & Hoard (1951). (f) Karle, Karle & Britts (1966). (g) Van der Helm, Sims & Seigler (1967). (h) Van der Helm, Hsu & Sims (1972). (i) Margulis & Fisher (1967). (j) Greenberg & Post (1968). (k) Adman & Margulis (1968). (l) Bock (1968). (m) Adman & Margulis (1969). (n) Margulis (1969). (o) Soltzberg & Margulis (1970). (p) Margulis (1972). (q) Benedetti, Corradini & Pedone (1970). (r) Margulis (1971). (s) Soltzberg & Margulis (1971).

With respect to the 1,3-transannular π interaction, the dithione should not be much different from the dione since the overlapping orbitals are both carbon $2p$. The dione has been examined by Riche & Janot (1972) and the 1,3-transannular distance is 2.078 (7) Å; the corresponding distance in the dithione is 2.071 (7) Å. Ballard & Park (1970) state that an increase in the 1,3-transannular distance of the dithione compared to the dione is a probable explanation for the difference in splitting. Since both transannular distances are the same (within experimental error), this cannot be the case.

An alternative explanation of the observed difference in $n \rightarrow \pi^*$ splitting could lie in a larger amplitude of the ring-puckering vibration for the dione than for the dithione. The ring puckering is opposed by the transannular 1,3 C...C nonbonded interactions and the CH₃...O or CH₃...S interactions. Since we have shown that the transannular 1,3 C...C distances are the same for both the dione and dithione compounds, then the difference in ring puckering would be due to a difference in CH₃...O and CH₃...S interaction.

The CH₃...O and CH₃...S distances are less than the sums of the van der Waals radii (Pauling, 1969), which are 3.40 and 3.85 Å respectively. Table 4 shows the amounts of additional compression resulting from ring puckering. Obviously the amount of compression in the dithione for a given puckering angle is much larger than the dione. Therefore, we expect a greater transannular carbon $2p$ interaction in the dione be-

cause of the larger puckering amplitude, leading to the observed $n \rightarrow \pi^*$ splitting.

The center of each molecule coincides with a crystallographic center of symmetry, as is usually true for simple planar cyclobutane compounds. This observation is in agreement with the general rule for predicting the conformation of cyclobutane compounds in the solid state (Margulis, 1969; Adman & Margulis, 1969): if the ring is not centrosymmetrically substituted, the ring will be puckered. Thus, if the ring is centrosymmetrically substituted, it may either be planar or puckered. The results of a literature search for all X-ray diffraction studies of simple cyclobutane structures are given in Table 3. All of the noncentrosymmetrically substituted structures have puckered rings as predicted by the rule. Most, but not all, of the centrosymmetrically substituted structures have planar rings.

It is expected that the ring atom in gaseous cyclobutane compounds should show a large thermal motion perpendicular to the plane of the ring. In the crystal, analysis of the r.m.s. components of thermal displacements for each atom (Table 5) shows that this is not the case in the present structure. The thionyl sulfur atom has large components of 'wagging' motion both in the plane of the cyclobutane ring and perpendicular to the plane of the cyclobutane ring. The methyl carbon atom also has sizable components of 'wagging' motion, and in addition it has a large 'scissoring' action.

The packing of the molecules is shown in Fig. 3. The symmetry-related molecules pack in sheets at $z=0$ and $z=\frac{1}{2}$. Each sheet has tetragonal packing. In the sheet at $z=\frac{1}{2}$, the molecules are centered over the holes in the $z=0$ sheet, and the cyclobutane ring planes are rotated by 90°. The intermolecular distances all appear to be of the normal van der Waals type.

The authors extend their gratitude to D. E. Sands and P. G. Lenhart for allowing us to use their ORTEP II programs, to the National Science Foundation for a fellowship (CDS), and to the Computer Center of the University of Louisville for putting computer time at their disposal.

Table 4. *Intramolecular distances minus the van der Waals radii (Å)*

Dihedral ring angle	CH ₃ ...S	CH ₃ ...O
180	-0.335	-0.217
175	-0.372	-0.293
170	-0.478	-0.373
165	-0.643	-0.452
160	-0.846	-0.532
155	-1.052	-0.611
150	-1.237	-0.688

Table 5. *R.m.s. component of thermal displacement in the direction defined by two atoms (Å)*

	Stretching		in plane of ring		Wagging out of plane of ring	
S(1)	0.245 (3)	S(1)-C(2)	0.371 (3)	C(3)-C(3')	0.378 (4)	C(4)-C(4')
C(2)	0.248 (5)	C(2)-C(3)	0.253 (7)	C(3)-C(3')	0.257 (8)	C(4)-C(4')
	0.243 (9)	C(2)-S(1)				
C(3)	0.242 (5)	C(3)-C(2)	0.254 (8)	C(2)-S(1)	0.269 (9)	C(4)-C(4')
	0.240 (6)	C(3)-C(2)				
C(4)	0.235 (7)	C(3)-C(4)	0.376 (7)	S(1)-C(2)	0.310 (7)	C(4)-C(4')
			0.245 (5)	C(3)-C(3')		

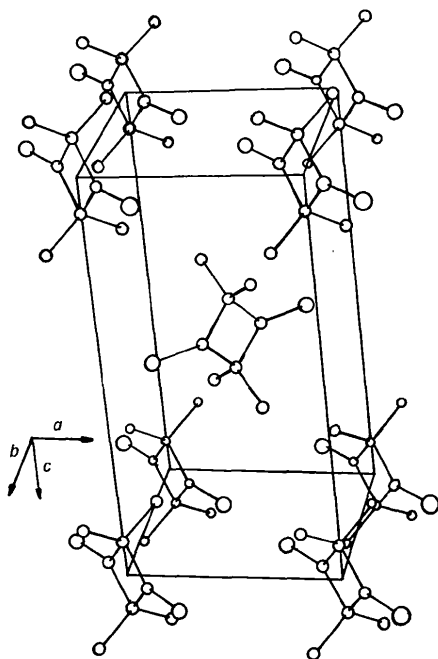

Fig. 3. The packing structure.

References

- ADMAN, E. & MARGULIS, T. N. (1968). *J. Amer. Chem. Soc.* **90**, 4517-4521.
- ADMAN, E. & MARGULIS, T. N. (1969). *J. Phys. Chem.* **73**, 1480-1484.
- BALLARD, R. E. & PARK, C. H. (1970). *Spectrochim. Acta* **26A**, 43-48.
- BENEDETTI, E., CORRADINI, P. & PEDONE, C. (1970). *Acta Cryst.* **B26**, 493-498.
- BOCK, C. M. (1968). *J. Amer. Chem. Soc.* **90**, 2748-2751.
- BUSING, W. R., MARTIN, K. O. & LEVY, H. A. (1962). *ORFLS, a Fortran Crystallographic Least-Squares Program*. Report ORNL-305, Oak Ridge National Laboratory, Oak Ridge, Tennessee.
- CASERIO, F. F. & ROBERTS, J. D. (1958). *J. Amer. Chem. Soc.* **80**, 5837-5840.
- CRUICKSHANK, D. W. J. (1961). *Acta Cryst.* **14**, 896-897.
- DUNITZ, J. D. (1949). *Acta Cryst.* **2**, 1-13.
- DUNITZ, J. D. & SCHOMAKER, V. (1952). *J. Chem. Phys.* **20**, 1703-1707.
- ELAM, E. U. & DAVIS, H. E. (1967). *J. Org. Chem.* **32**, 1562-1565.
- FERGUSON, L. N. & NNADI, J. N. (1965). *J. Chem. Ed.* **42**, 529-535.
- FRIEDLANDER, P. H. F. & ROBERTSON, J. M. (1956). *J. Chem. Soc.* pp. 3083-3087.
- GREENBERG, B. & POST, B. (1968). *Acta Cryst.* **B24**, 918-924.
- HANSON, H. P., HERMAN, F., LEA, J. D. & SKILLMAN, S. (1964). *Acta Cryst.* **17**, 1040-1050.
- JOHNSON, C. K. (1965). *ORTEP, a Fortran Thermal Ellipsoid Plot Program for Crystal Structure Illustration*. Report ORNL-3794, Oak Ridge National Laboratory, Oak Ridge, Tennessee.
- KARLE, I. L., KARLE, J. & BRITTS, K. (1966). *J. Amer. Chem. Soc.* **88**, 2918-2921.
- KOSOWER, E. M. (1963). *J. Chem. Phys.* **38**, 2813-2815.
- MARGULIS, T. N. (1965). *Acta Cryst.* **19**, 857-859.
- MARGULIS, T. N. (1969). *Chem. Commun.* pp. 215-216.
- MARGULIS, T. N. (1971). *J. Amer. Chem. Soc.* **93**, 2193-2196.
- MARGULIS, T. N. (1972). Private communication.
- MARGULIS, T. N. & FISHER, M. (1967). *J. Amer. Chem. Soc.* **89**, 223-226.
- OWEN, J. B. & HOARD, J. L. (1951). *Acta Cryst.* **4**, 172-176.
- PARRISH, W. & WILSON, A. J. C. (1967). In *International Tables for X-ray Crystallography*. Vol. II, pp. 220-225. Birmingham: Kynoch Press.
- PAULING, L. (1960). *The Nature of the Chemical Bond*. Ithaca: Cornell Univ. Press.
- RATHJENS, W. D., FREEMAN, N. K., GUINN, W. D. & PITZER, K. S. (1953). *J. Amer. Chem. Soc.* **75**, 5634-5642.
- RICHE, M. C. & JANOT, M. M. (1972). *C. R. Acad. Sci. Paris, Sér. C*, **275**, 543-546.
- SCHOMAKER, V. & TRUEBLOOD, K. N. (1969). *Acta Cryst.* **B24**, 63-76.
- SILVERSMITH, E. F. & ROBERTS, J. D. (1958). *J. Amer. Chem. Soc.* **80**, 4083-4091.
- SOLTZBERG, L. & MARGULIS, T. N. (1970). *Abstr. Amer. Cryst. Assoc. Meeting, Ottawa*, p. 54.
- SOLTZBERG, L. & MARGULIS, T. N. (1971). *J. Chem. Phys.* **55**, 4907-4913.
- SMUTNY, E. J., CASERIO, M. C. & ROBERTS, J. D. (1960). *J. Amer. Chem. Soc.* **82**, 1793-1801.
- STEWART, R. F., DAVIDSON, E. R. & SIMPSON, W. T. (1965). *J. Chem. Phys.* **42**, 3175-3187.
- VAN DER HELM, D., HSU, I.-N. & SIMS, J. J. (1972). *Acta Cryst.* **B28**, 3109-3114.
- VAN DER HELM, D., SIMS, J. J. & SEIGLER, D. S. (1967). *Abstr. Amer. Cryst. Assoc. Meeting, Minneapolis*, p. 93.
- WILLIAMS, D. E. (1964). *LCR-2, a Fortran Lattice Constant Refinement Program*. U. S. Atomic Energy Commission, Report IS-1052.
- WILLIAMS, D. E. & RUNDLE, R. E. (1964). *J. Amer. Chem. Soc.* **86**, 1660-1666.